

IZAR RC i G4

RADIO | RADIO MODULE

DIEHL
Metering



APPLICATION

The new generation of IZAR Radio Compact Inductive G4 is designed for mobile reading and long range fixed network remote reading of Diehl Metering water meters. IZAR RC i G4 radio module can be clipped onto all the meters of the Diehl Metering inductive modular range (Ha+Ti or Ti) with a grey or red ring. It comprises a tamper-proof sensor operating on inductive principle. Easy to fit, IZAR RC i G4 integrates the standardized OMS protocol and can be field or factory programmable. IZAR RC i G4 radio module transmits the meter reading, via a unidirectional link every 12 seconds in R3 mode and every 15 minutes in long-range fixed network R4 mode enabling an efficient drive-by reading and an accurate fixed network. IZAR RC i G4 offers multiple functions (current index, 11 historical index values and detailed leaks) and alarms (leaks detection, meter stopped, low battery...).

FEATURES

- ▶ Compact radio emitter, OMS protocol
- ▶ Compatible with Diehl Metering water meters
- ▶ Available in 868 MHz and 434 MHz
- ▶ Suitable for mobile reading and long-range fixed network
- ▶ IP 68
- ▶ Lifetime up to 15 years
- ▶ Detailed leaks information
- ▶ 11 historical index values
- ▶ Different functions and alarms available
- ▶ Insensitive to magnetic fraud

IZAR RC i G4

RADIO | RADIO MODULE

PRINCIPLE OF OPERATION

IZAR RC i G4 includes an electronic circuit that collects the data coming from a Diehl Metering water meter and transmits in real time the index and other operating information every 12 seconds in R3 mode and every 15 minutes in long-range fixed network R4 mode.

Mobile reading in Walk-by / Drive-by / Passive Drive-by:

The data sent by IZAR RC i G4 is collected using either a handheld computer or tablet equipped with an IZAR RECEIVER BT for Walk-by/ Drive-by or an IZAR RDC VEHICLE for passive Drive-by. Data is then transferred directly to a centralized monitoring system.

Fixed network :

A fixed receiver IZAR RDC STANDARD/IZAR RDC BATTERY (fixed network R3) or IZAR RDC PREMIUM (long-range fixed network R4) installed in a building will collect the data and send it at predefined intervals via GPRS or LAN, to a centralized server. Reading through M-Bus application with an IZAR CENTER associated to an IZAR RECEIVER M-BUS and IZAR@NET 2 software, is possible as well.

TECHNICAL DATA

IZAR RC i G4	
Communication protocol	OMS Volume 2 Version 3.0.1
Frequency	868.95 or 434.47 MHz (R3 mode) 868.30 or 433.42 MHz (R4 mode)
Modulation	FSK
Transmission power	16 mW (868 MHz) 10 mW (434 MHz)
Transmission mode	unidirectional
Radio range	Up to 500 m depending on ambient conditions
Standards	EN 300 220, CE, RED directive, EN 13757-3/-4
Power supply	Lithium battery 3.6 V
Battery lifetime	Up to 12 years

AMBIENT CONDITIONS

IZAR RC i G4	
Operating temperature range	°C -15 ... +55
Storage temperature range	°C -20 ... +70
Ambient humidity	% 0 ... 70 (non-condensing)
Protection class	IP 68

CONFIGURATION

IZAR RC i G4	
Interface	Optical IrDa
Functions	Current index 11 historical index values (yearly, monthly, weekly or daily) detailed leaks information: numbers of leaks, number of leaks day, date of the last leak, estimated volume of the leak(s) ...
Alarms management	Leak detection Mechanical tampering Meter stopped Overflow Underflow Backflow Low battery indicator

COMPATIBILITY

IZAR RC i G4	
Meters	Diehl Metering inductive modular range Ha+Ti or Ti . Pulse weight DN 15 to DN 40 (1 liter) Pulse weight DN 50 to DN 125 (10 liters) Pulse weight DN 150 to DN 300 (100 liters)

IZAR RC i G4

RADIO | RADIO MODULE

DIMENSIONS

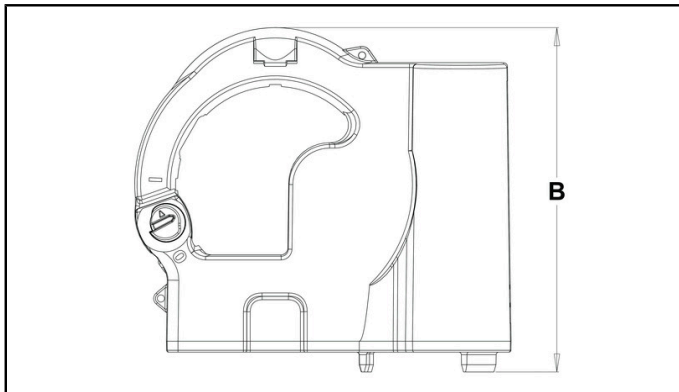
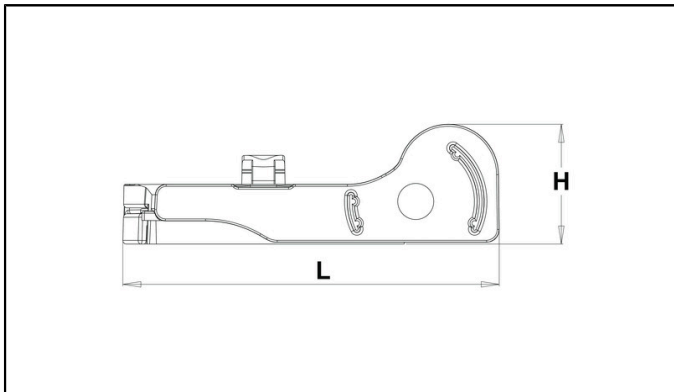

IZAR RC i G4			
Length	L	mm	104
Height	H	mm	33
Width	B	mm	95